

## APPROVAL SHEET

AOT MODEL NAME	4206
AOT PART NUMBER	4206C-W30C
CUSTOMER NAME	General
DATE	2021 / Oct
VERSION	01

MAKER			CUSTOMER			
Prepared	Checked	Approved				
<b>Sam Kuo</b>	<b>Claire Hung</b>	<b>Sinfan Lo</b>				

**AOT Headquarters**  
No. 13, Gongye 5th. Road, Hsinchu Industrial Park, Hukou Shiang,  
Hsinchu Hsien 303, Taiwan, R.O.C.  
TEL: +886-3-597-6988 / FAX: +886-3-598-7392



Solid-State Light. Done Right.

**Revision Note**

Date	Revision	Page	Version
2021-10-15	Initiate Document	-	01

## Package Outline

Model name: 4206C-W30C

Unit: mm, Tolerance:  $\pm 0.1$  mm

Front view

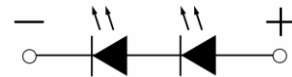
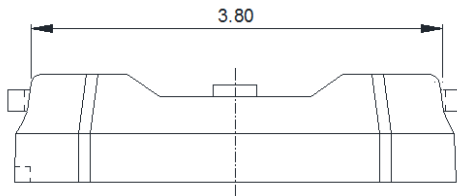

Top view

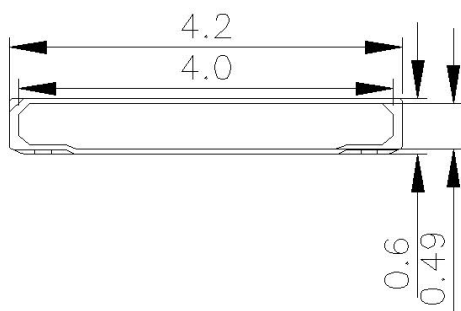

Back view

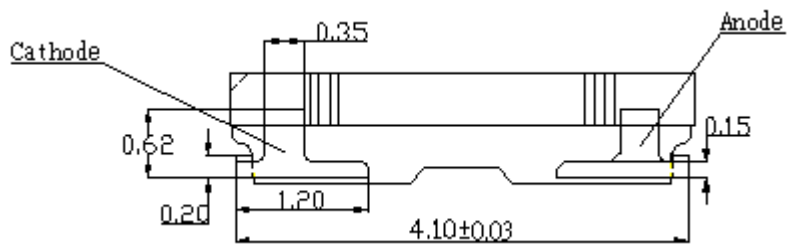

Side view

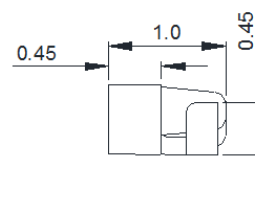

## Recommended Soldering Pad design (Unit: mm)

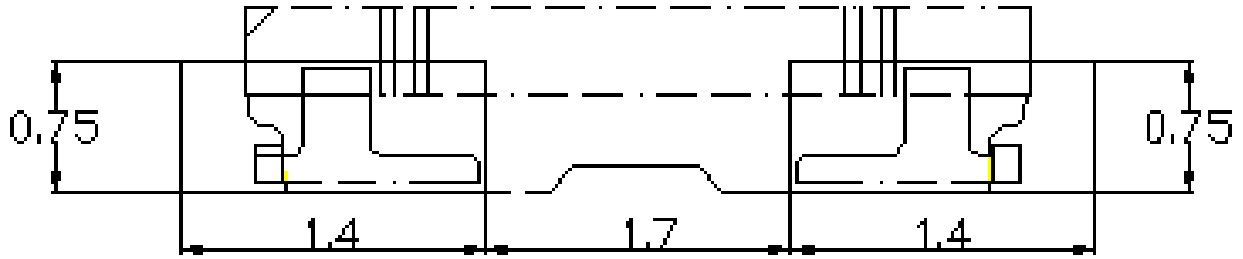

Item	Materials
Package	High Temperature Resistant Plastic, PPA.
Encapsulating	Silicone Resin(with phosphor)
Electrode	Cu Alloy With Ni, Ag Plating.

- SMD type Side-View white LED.
- Lead frame package with individual 2 pins.
- Wide viewing angle(120°)
- Compatible with reflow soldering.
- Complies with RoHS Directive.
- The Encapsult surface should be under the package surface, and should not expose the wire.
- Compact package outline (L x W x H) of 4.2 mm x 1.00mm x 0.6 mm.

## Optical/ Electronic Characteristics (T<sub>A</sub>= 25°C)

Item	Symbol	Condition	Min	Typ	Max	Unit
Forward Voltage	V <sub>F</sub>	I <sub>F</sub> =20mA	5.4	-	5.8	V
Luminous Flux	Φ <sub>V</sub>	I <sub>F</sub> =20mA	13.00	-	19.00	lm
Reverse Current	I <sub>R</sub>	V <sub>R</sub> = -7V	-	-	0.05	μA

\* Tolerance of measurements of the Forward Voltage is ± 0.05 V.

\* Tolerance of measurements of the Luminous Flux is ± 5%.

## Absolute Maximum Ratings (T<sub>A</sub>= 25°C)

Item	Symbol	Absolute Maximum Rating	Unit
Forward Current	I <sub>F</sub>	30	mA
*Pulse Forward Current	I <sub>FP</sub>	100	mA
*Reverse Voltage	V <sub>R</sub>	5	V
Power Dissipation	P <sub>D</sub>	174	mW
Operating Temperature	T <sub>opr</sub>	-30~+65	°C
Storage Temperature	T <sub>stg</sub>	-40~+100	°C
Soldering Temperature	T <sub>sld</sub>	Reflow Soldering : 260°C for 10sec Hand Soldering : 350°C for 3sec	
Junction Temperature	T <sub>j</sub>	105	°C
Forward Voltage at Low Current	VF2	>4.0 ( @1uA )	V

\* I<sub>FP</sub> Conditions: Pulse Width ≤ 10msec, and duty ≤ 1/10

\* Max condition is not guarantee for life time

## Group Definition of Forward Voltage

Rank	Condition	VF(V)	
V15	T <sub>S</sub> =25°C I <sub>F</sub> =20mA	5.4	5.6
V16		5.6	5.8

## Group Definition of Brightness

Rank	Condition	Luminous Flux	
		φ <sub>v</sub> (lm)	
		Min.	Max.
K130	T <sub>A</sub> =25°C I <sub>F</sub> =20mA	13.00	13.50
K135		13.50	14.00
K140		14.00	14.50
K145		14.50	15.00
K150		15.00	15.50
K155		15.50	16.00
K160		16.00	16.50
K165		16.50	17.00
K170		17.00	17.50
K175		17.50	18.00
K180		18.00	18.50
K185		18.50	19.00

\*A shipment shall consist of LEDs in a combination of above ranks.

\*The percentage of each rank in the shipment shall be determined by AOT.

\*The ranking information of LEDs can be found on the reel label.

## Group Definition of Chromaticity Coordinate

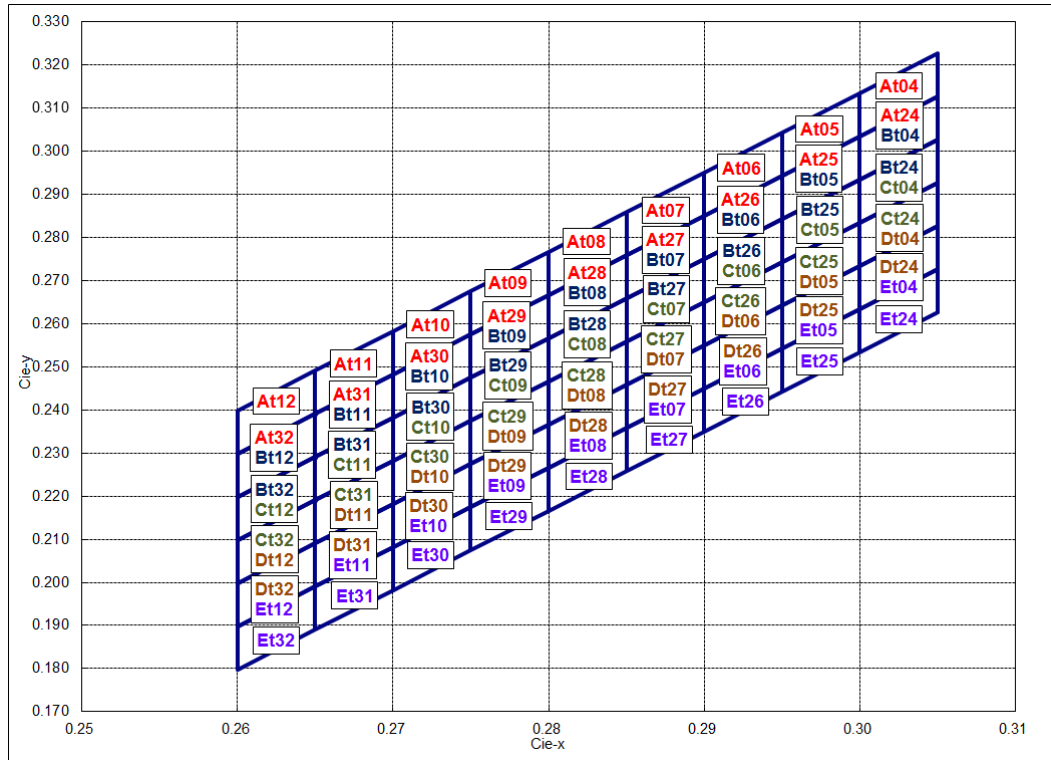

Rank	x	y	Rank	x	y	Rank	x	y
At04	0.3000	0.3034	Bt04 At24	0.3000	0.2934	Bt24 Ct04	0.3000	0.2834
	0.3000	0.3134		0.3000	0.3034		0.3000	0.2934
	0.3050	0.3226		0.3050	0.3126		0.3050	0.3026
	0.3050	0.3126		0.3050	0.3026		0.3050	0.2926
At05	0.2950	0.2942	Bt05 At25	0.2950	0.2842	Bt25 Ct05	0.2950	0.2742
	0.2950	0.3042		0.2950	0.2942		0.2950	0.2842
	0.3000	0.3134		0.3000	0.3034		0.3000	0.2934
	0.3000	0.3034		0.3000	0.2934		0.3000	0.2834
At06	0.2900	0.2850	Bt06 At26	0.2900	0.2750	Bt26 Ct06	0.2900	0.2650
	0.2900	0.2950		0.2900	0.2850		0.2900	0.2750
	0.2950	0.3042		0.2950	0.2942		0.2950	0.2842
	0.2950	0.2942		0.2950	0.2842		0.2950	0.2742
At07	0.2850	0.2758	Bt07 At27	0.2850	0.2658	Bt27 Ct07	0.2850	0.2558
	0.2850	0.2858		0.2850	0.2758		0.2850	0.2658
	0.2900	0.2950		0.2900	0.2850		0.2900	0.2750
	0.2900	0.2850		0.2900	0.2750		0.2900	0.2650
At08	0.2800	0.2666	Bt08 At28	0.2800	0.2566	Bt28 Ct08	0.2800	0.2466
	0.2800	0.2766		0.2800	0.2666		0.2800	0.2566
	0.2850	0.2858		0.2850	0.2758		0.2850	0.2658
	0.2850	0.2758		0.2850	0.2658		0.2850	0.2558

Rank	x	y	Rank	x	y	Rank	x	y
At09	0.2750	0.2574	Bt09 At29	0.2750	0.2474	Bt29 Ct09	0.2750	0.2374
	0.2750	0.2674		0.2750	0.2574		0.2750	0.2474
	0.2800	0.2766		0.2800	0.2666		0.2800	0.2566
	0.2800	0.2666		0.2800	0.2566		0.2800	0.2466
At10	0.2700	0.2482	Bt10 At30	0.2700	0.2382	Bt30 Ct10	0.2700	0.2282
	0.2700	0.2582		0.2700	0.2482		0.2700	0.2382
	0.2750	0.2674		0.2750	0.2574		0.2750	0.2474
	0.2750	0.2574		0.2750	0.2474		0.2750	0.2374
At11	0.2650	0.2390	Bt11 At31	0.2650	0.2290	Bt31 Ct11	0.2650	0.2190
	0.2650	0.2490		0.2650	0.2390		0.2650	0.2290
	0.2700	0.2582		0.2700	0.2482		0.2700	0.2382
	0.2700	0.2482		0.2700	0.2382		0.2700	0.2282
At12	0.2600	0.2298	Bt12 At32	0.2600	0.2198	Bt32 Ct12	0.2600	0.2098
	0.2600	0.2398		0.2600	0.2298		0.2600	0.2198
	0.2650	0.2490		0.2650	0.2390		0.2650	0.2290
	0.2650	0.2390		0.2650	0.2290		0.2650	0.2190
Ct24 Dt04	0.3000	0.2734	Dt24 Et04	0.3000	0.2634	Et24 Ft04	0.3000	0.2534
	0.3000	0.2834		0.3000	0.2734		0.3000	0.2634
	0.3050	0.2926		0.3050	0.2826		0.3050	0.2726
	0.3050	0.2826		0.3050	0.2726		0.3050	0.2626
Ct25 Dt05	0.2950	0.2642	Dt25 Et05	0.2950	0.2542	Et25 Ft05	0.2950	0.2442
	0.2950	0.2742		0.2950	0.2642		0.2950	0.2542
	0.3000	0.2834		0.3000	0.2734		0.3000	0.2634
	0.3000	0.2734		0.3000	0.2634		0.3000	0.2534
Ct26 Dt06	0.2900	0.2550	Dt26 Et06	0.2900	0.2450	Et26 Ft06	0.2900	0.2350
	0.2900	0.2650		0.2900	0.2550		0.2900	0.2450
	0.2950	0.2742		0.2950	0.2642		0.2950	0.2542
	0.2950	0.2642		0.2950	0.2542		0.2950	0.2442
Ct27 Dt07	0.2850	0.2458	Dt27 Et07	0.2850	0.2358	Et27 Ft07	0.2850	0.2258
	0.2850	0.2558		0.2850	0.2458		0.2850	0.2358
	0.2900	0.2650		0.2900	0.2550		0.2900	0.2450
	0.2900	0.2550		0.2900	0.2450		0.2900	0.2350
Ct28 Dt08	0.2800	0.2366	Dt28 Et08	0.2800	0.2266	Et28 Ft08	0.2800	0.2166
	0.2800	0.2466		0.2800	0.2366		0.2800	0.2266
	0.2850	0.2558		0.2850	0.2458		0.2850	0.2358
	0.2850	0.2458		0.2850	0.2358		0.2850	0.2258

If color binning is required, only one color group is allowed for each chip within a reel.

Chromaticity coordinate groups are measured with an accuracy of +/-0.005



Rank	x	y	Rank	x	y	Rank	x	y
Ct29 Dt09	0.2750	0.2274	Dt29 Et09	0.2750	0.2174	Et29 Ft09	0.2750	0.2074
	0.2750	0.2374		0.2750	0.2274		0.2750	0.2174
	0.2800	0.2466		0.2800	0.2366		0.2800	0.2266
	0.2800	0.2366		0.2800	0.2266		0.2800	0.2166
Ct30 Dt10	0.2700	0.2182	Dt30 Et10	0.2700	0.2082	Et30 Ft10	0.2700	0.1982
	0.2700	0.2282		0.2700	0.2182		0.2700	0.2082
	0.2750	0.2374		0.2750	0.2274		0.2750	0.2174
	0.2750	0.2274		0.2750	0.2174		0.2750	0.2074
Ct31 Dt11	0.2650	0.2090	Dt31 Et11	0.2650	0.1990	Et31 Ft11	0.2650	0.1890
	0.2650	0.2190		0.2650	0.2090		0.2650	0.1990
	0.2700	0.2282		0.2700	0.2182		0.2700	0.2082
	0.2700	0.2182		0.2700	0.2082		0.2700	0.1982
Ct32 Dt12	0.2600	0.1998	Dt32 Et12	0.2600	0.1898	Et32 Ft12	0.2600	0.1798
	0.2600	0.2098		0.2600	0.1998		0.2600	0.1898
	0.2650	0.2190		0.2650	0.2090		0.2650	0.1990
	0.2650	0.2090		0.2650	0.1990		0.2650	0.1890

If color binning is required, only one color group is allowed for each chip within a reel.

Chromaticity coordinate groups are measured with an accuracy of +/-0.005

## Optical and electrical characteristics

**Forward Voltage vs. Forward Current (Ta=25°C)**

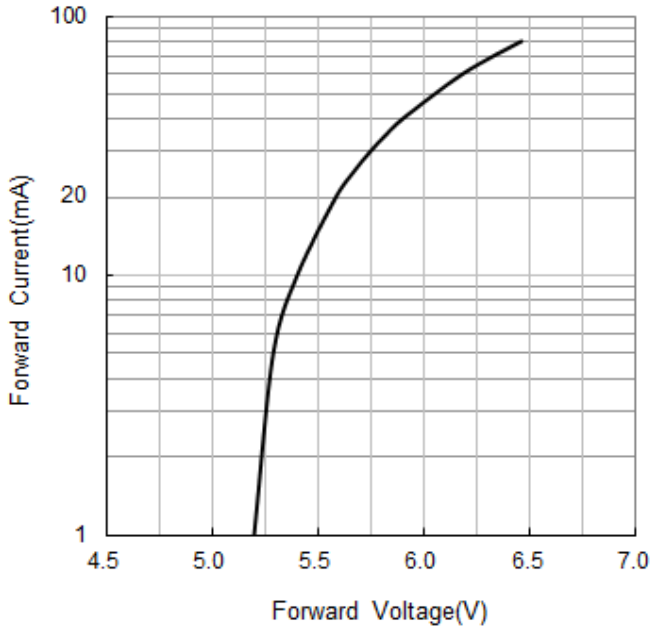

**Forward Current vs. Relative Luminous Flux**

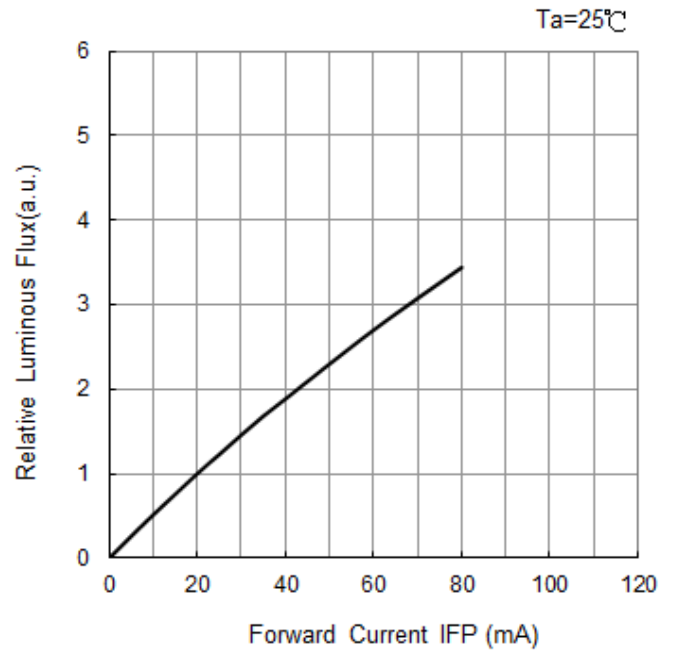

**Ambient Temperature vs. Forward Voltage**

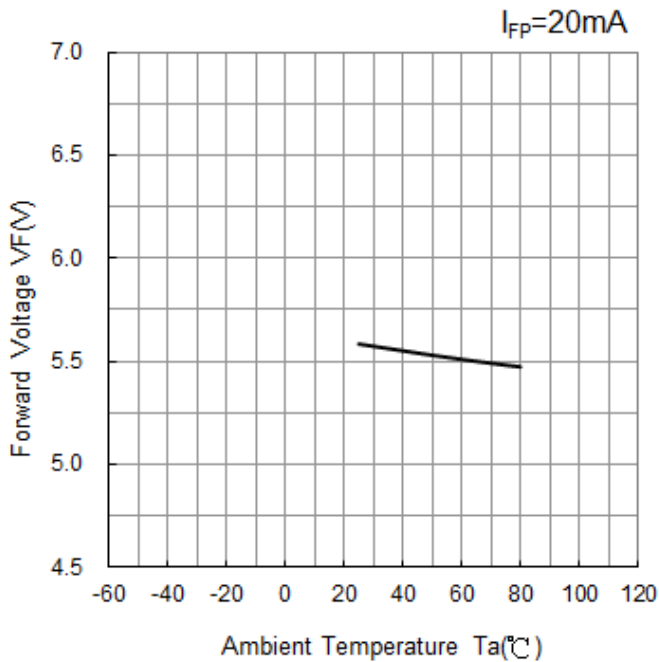

**Ambient Temperature vs. Relative Luminous**

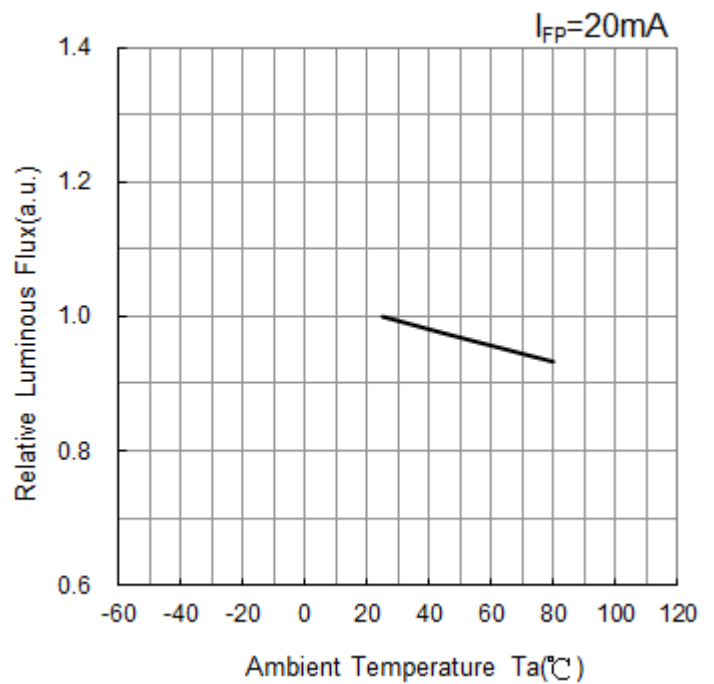

### Forward Current vs. Chromaticity Coordinate ( $T_A = 25^\circ\text{C}$ )

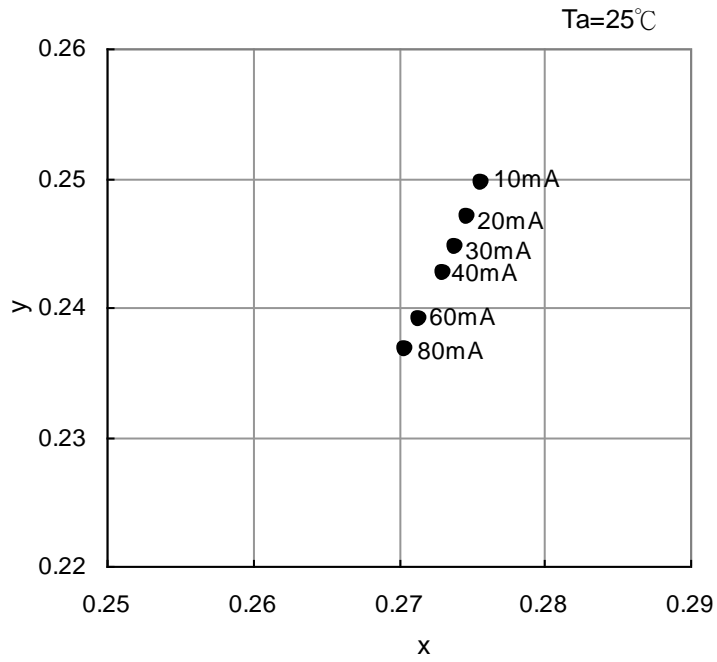

### Ambient Temperature vs. Chromaticity Coordinate ( $I_{FP} = 20\text{mA}$ )

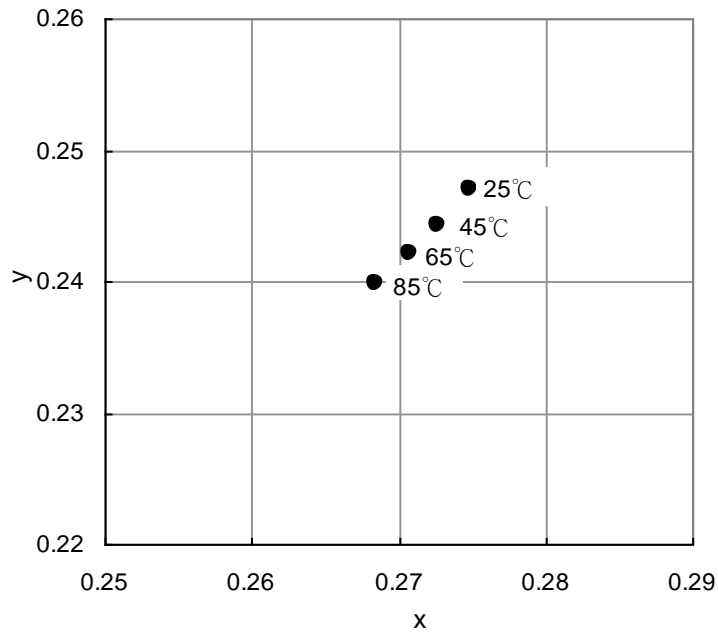

## Spectrum ( $T_A=25^\circ\text{C}$ , $I_{FP}=20\text{mA}$ )

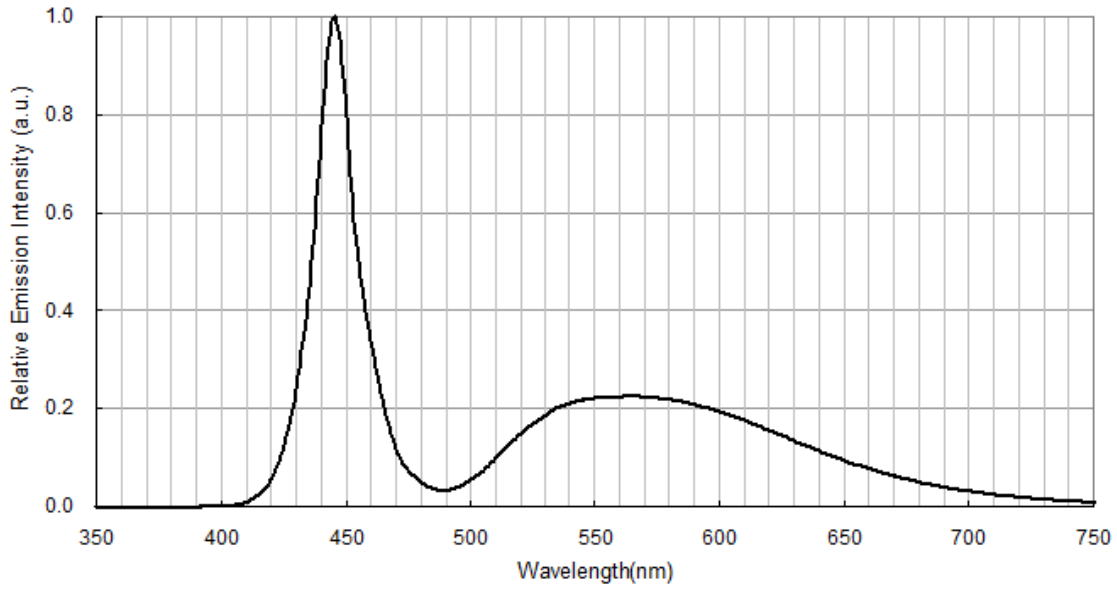

## Radiation Pattern ( $T_A=25^\circ\text{C}$ , $I_{FP}=20\text{mA}$ )

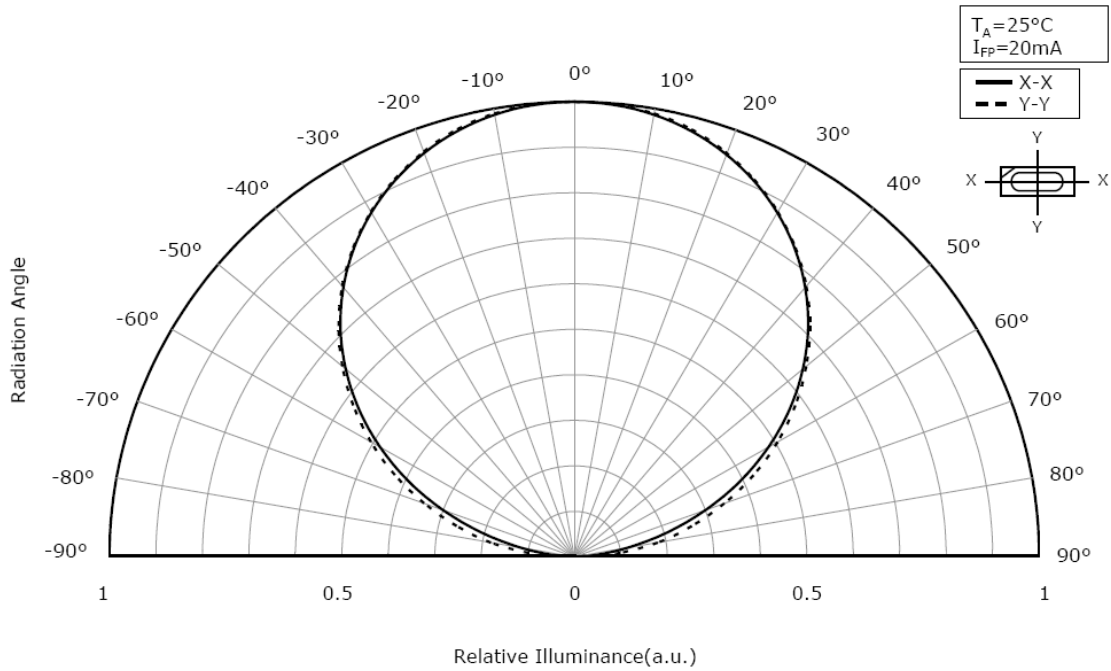

## Recommended Reflow Soldering Conditions

### Surface Mounting Condition

In automatic mounting of the SMD LEDs on printed circuit boards, any bending, expanding and pulling forces or shock against the SMD LEDs should be kept min. to prevent them from electrical failures and mechanical damages of the devices.

### Soldering Reflow

- Soldering of the SMD LEDs should conform to the soldering condition in the individual specifications.
- SMD LEDs are designed for Reflow Soldering.
- In the reflow soldering, too high temperature and too large temperature gradient such as rapid heating/cooling may cause electrical & optical failures and damages of the devices.
- AOT cannot guarantee the LEDs after they have been assembled using the solder dipping method.

### 1) Lead Solder

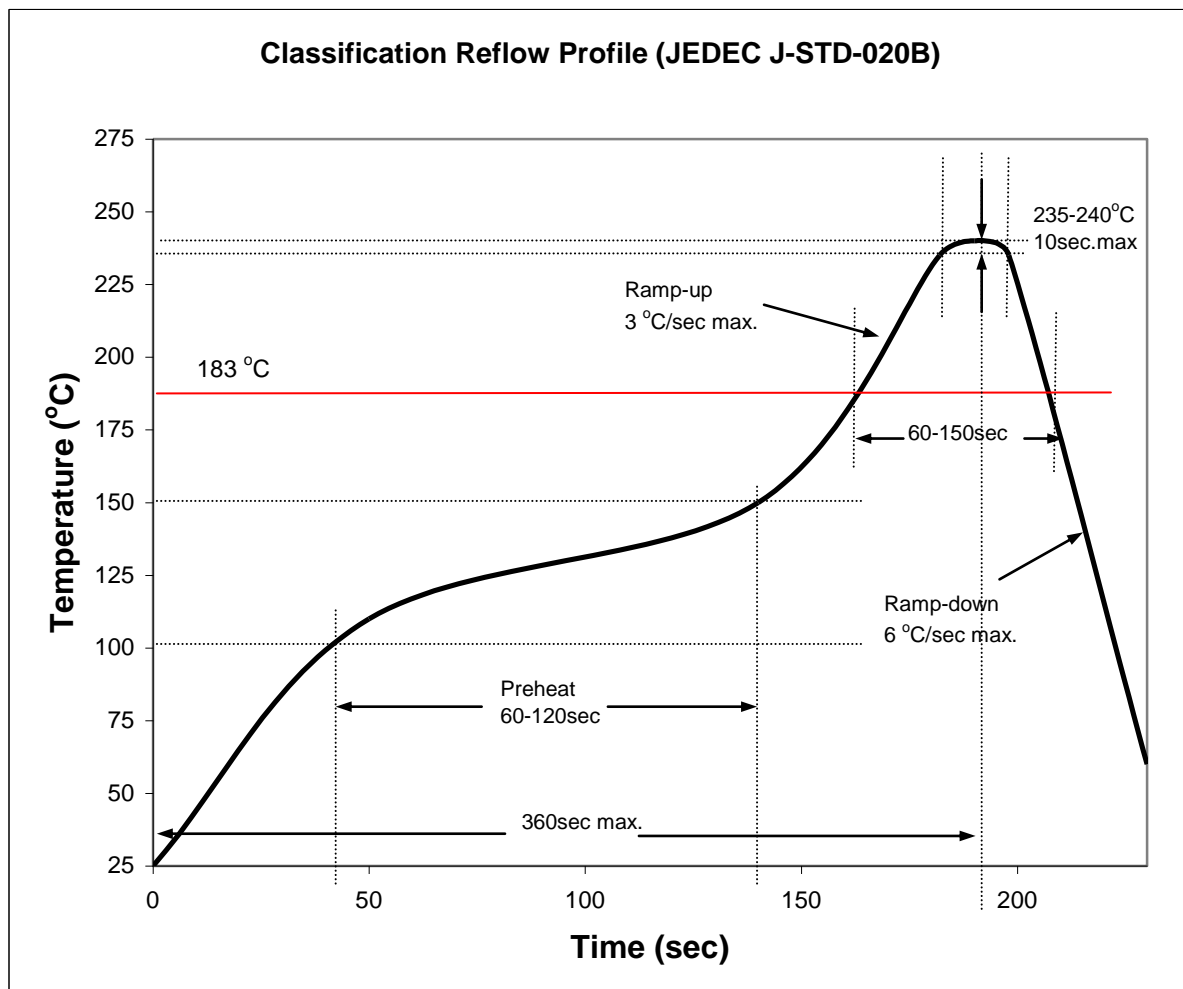

## 2) Lead-Free Solder

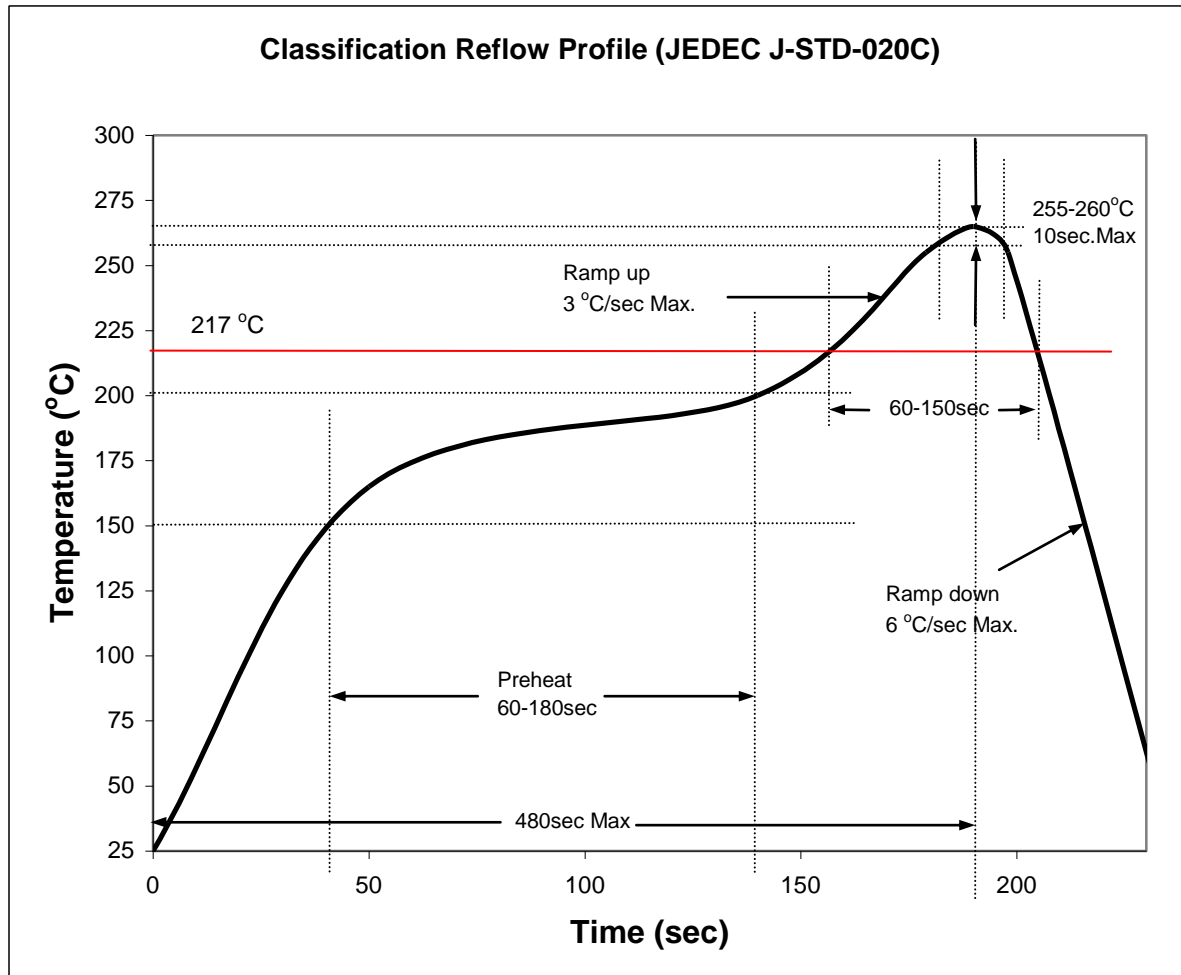

## 3) Manual Soldering Conditions

### - Lead Solder

Max. 300 °C for Max. 3sec, and only one time.

### - Lead-free Solder

Max. 350 °C for Max. 3sec, and only one time.

- There is possibility that the brightness of LEDs is decreased, which is influenced by heat or ambient atmosphere during reflow. It is recommended to use the nitrogen reflow method.

- After LEDs have been soldered, repair should not be done. As repair is unavoidable, a double-head soldering iron should be used. It should be confirmed beforehand whether the characteristics of the LEDs will be damaged by repairing or not.

- Reflow soldering should not be done more than two times.

## Dimensions (Unit :mm)

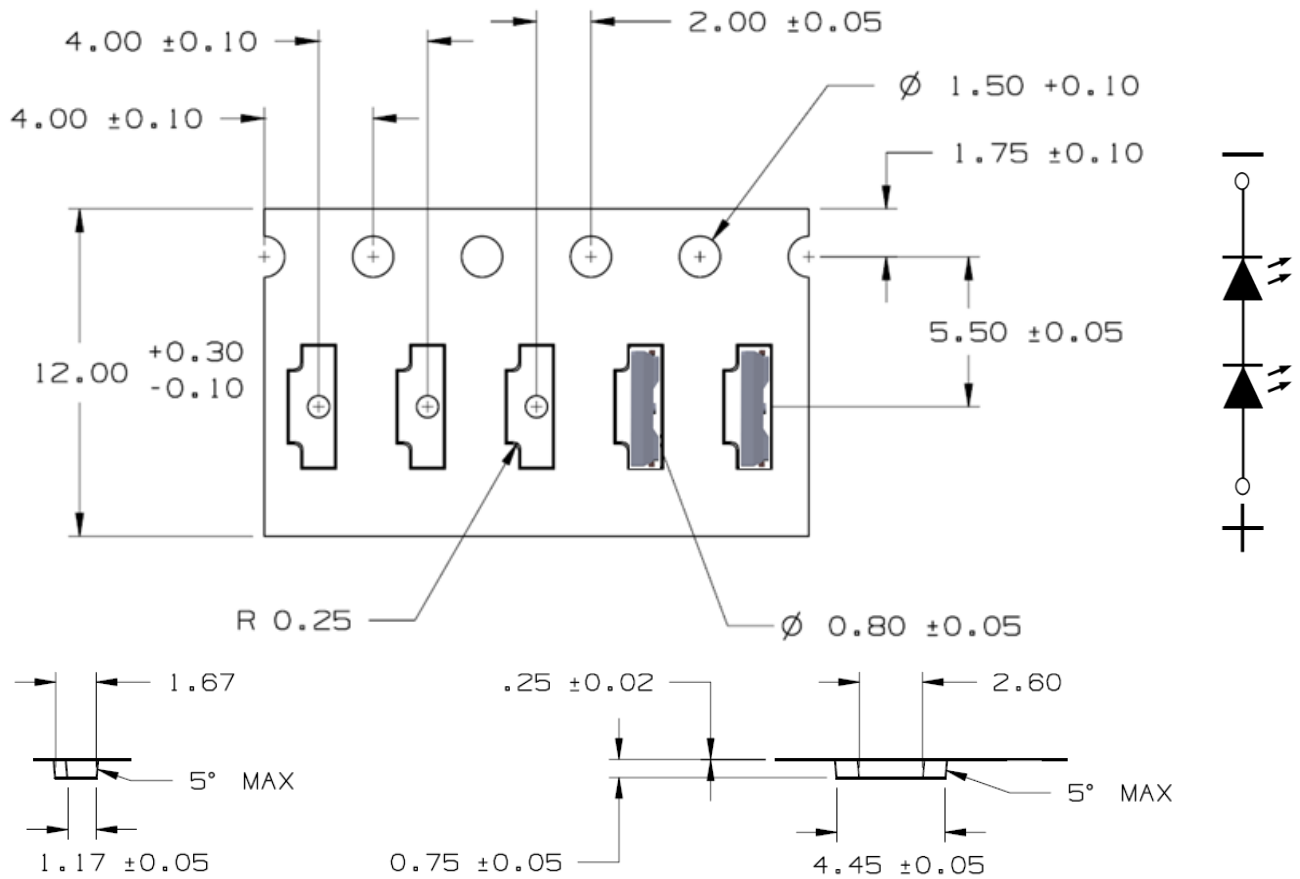

Item	Spec.	Tolerance(mm)	Item	Spec.	Tolerance(mm)
W	12.0	+0.30/-0.10	P2	2.00	±0.05
E	1.75	±0.10	P0x10	40.0	-
F	5.50	±0.05	t	0.25	±0.02
D0	1.50	±0.10	A0	1.17	±0.05
D1	0.8	±0.05	B0	4.45	±0.05
P0	4.00	±0.10	K0	0.75	±0.05
P1	4.00	±0.10			

## Packing Formation

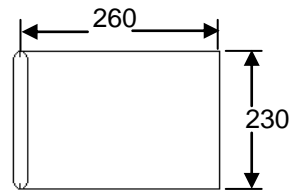
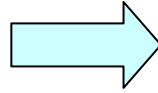
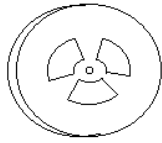

Diameter : 178 mm  
Width : 8 mm  
4206C-W30C  
⇒ 4,000 pcs/Reel

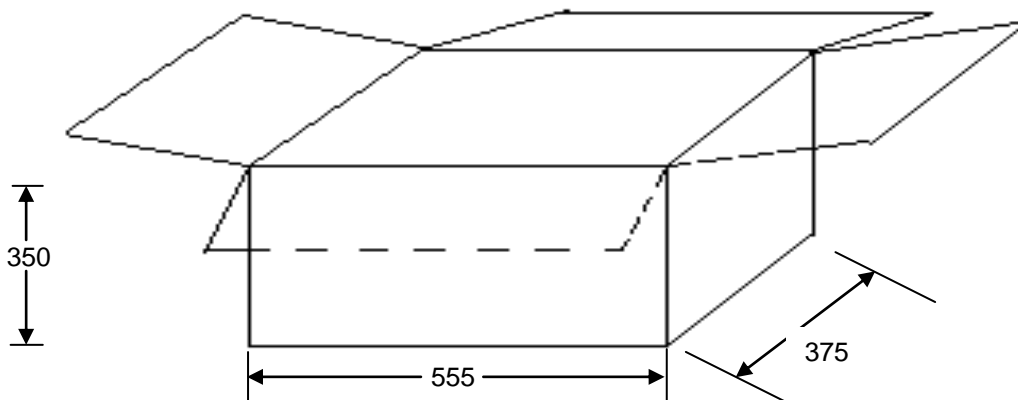
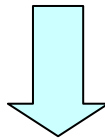

Aluminum Bag, Anti-Static Shielding  
1 Reel / Bag ( T = 0.1 mm )





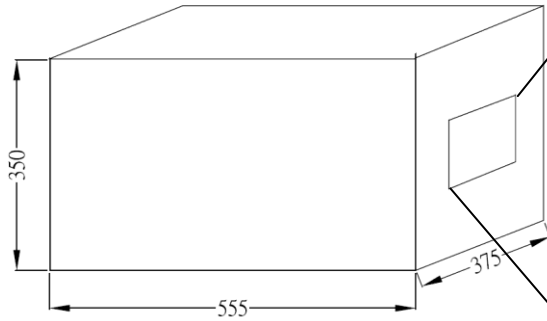

## Package Outlook:



 Solid-State Light. Done Right. Advanced Optoelectronic Technology Inc.	
Customer	
PO No.	
Part No.	
Quantity	
Packing Date	
Carton No.	
Ship No.	
QC Check	 
備註	

## Reel Label Definition

SMD LED Part Number : XXXXX-XXXX Brightness : A CIE : B VF : C Quantity : nn ea Serial No : SM0yymmddxxxx  Cust. PN. : XXXXX-XXXX	SAP. No.    
--	---

- A : Iv value
- B : CIE value noted,
- C : Vf value,
- nn : Quantity of LED

SM0yymmddxxxx : yy : year, mm : month, dd : day, xxxx : reel no

\*Reel Label to fill in practice data of all LED characteristic

## Reliability Test

No.	Test Item	Standard Test Method	Test Condition	Note	Number of Damaged
1	Room Temp. Life Test	Internal Ref.	$T_A=25^{\circ}\text{C}, I_F=20\text{mA}$	1000hrs	0/20
2	High Temp. Storage	JESD22-A103	$T_A=100^{\circ}\text{C}$	1000hrs	0/20
3	High Temp. Operating	JESD22-A108	$T_A=65^{\circ}\text{C}, I_F=20\text{mA}$	1000hrs	0/20
4	Low Temp. Operating	JESD22-A108	$T_A=-40^{\circ}\text{C}, I_F=20\text{mA}$	1000hrs	0/20
5	High Temp. and High Humidity Operation	JESD22-A119	$60^{\circ}\text{C}$ 90%RH, $I_F=20\text{mA}$	1000hrs	0/20
6	Thermal Cycle Test	JESD22-A106	$100^{\circ}\text{C}$ 30min~ $-40^{\circ}\text{C}$ 30min Transform time 5min	300cycles	0/200
7	Reflow Test	Internal Ref.	Reflow $260^{\circ}\text{C}$ → HTOL $140^{\circ}\text{C}$ 2min	2 cycles	0/500

## Criteria for Judging Damage

Item	Symbol	Test Conditions	Criteria for Judgment	
			Min.	Max.
Forward Voltage	$V_F$	$I_F=20\text{mA}$	-	*U.S.Lx1.1
Reverse Current	$I_R$	$V_R=5\text{V}$	-	*U.S.Lx2.0
Luminous Intensity	$\Phi_V$	$I_F=20\text{mA}$	*L.S.Lx0.7	-

\* U.S.L: Upper Standard Level

\* L.S.L: Lower Standard Level

## Side View Process Flow

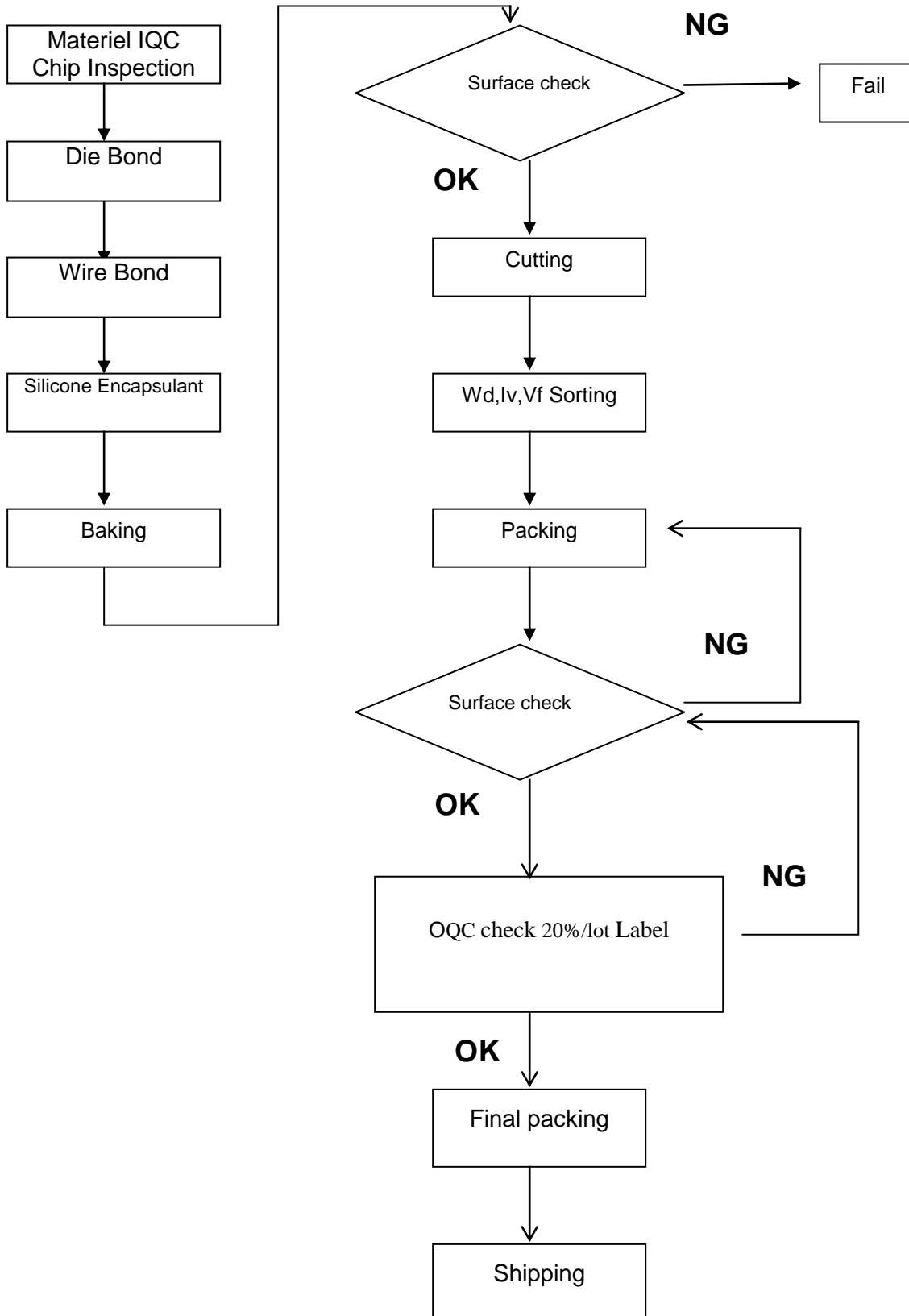

## **CAUTIONS**

### (1) Moisture Proof Package

The moisture proof package should be used to prevent moisture in the package as the moisture may Cause damage to optical characteristics of the LEDs.

The aluminum bag with zipper is used for moisture proof package. And, the moisture absorbent Material, Silica gel, is inserted into aluminum bag.

### (2) Storage:

Storage Conditions

Before opening the package:

The LEDs should be kept at 30°C or less than 90%RH or less. The LEDs should be used within a year. When storing the LEDs, moisture proof packaging with absorbent material is recommended.

After opening the package:

After open the package, the LED should be kept at 30°C, 60%RH or less. The LED should be soldered within 168 hours (7 days) after opening the package. If unused LEDs remain, it should be stored in moisture proof condition.

### (3) Heat Generation

Thermal design of the end products is of paramount importance. The heat generation must be taken into design consideration when using the LED. The coefficient of the temperature increase per input electric power is affected by the thermal resistance of the circuit board and density of LED placement on the board, as well as other components.

### (4) Static Electricity

Static electricity or surge voltage damages the LEDs. All equipment and machinery must be properly grounded. It is recommended to use a wristband or anti-electrostatic glove when handling the LEDs. When inspecting the final products in which LEDs were assembled, it is recommended to check whether the assembled LEDs are damaged by static electricity or not. It is easy to find static-damaged LEDs by a light-on test or a Vf test at a lower current. (Below 1mA is recommended).  
Criteria: Vf >3.8 V at If=0.01mA

### (5) Cleaning

Use isopropyl alcohol as a solvent for cleaning the LEDs. The other solvent may dissolve the LEDs package and the epoxy.

Ultrasonic cleaning should not be done.

### (6) Electrostatic Discharge (ESD)

The products are sensitive to static electricity or surge voltage, An ESD event may damage its die or reduce its reliability performance. When handling the products, measures against electro static discharge, including the followings, are strongly recommended.

Eliminating the charge;

Wrist strap, ESD footwear and garments, ESD floors

Grounding the equipment and tools at workstation

ESD table / shelf mat (conductive materials)

Proper grounding techniques are required for all devices, equipment and machinery used in the assembly of the products, Also note that surge protection should be considered in the design of customer products.

If tools or equipment contain insulating materials, such as glass or plastic, proper measures against electro static discharge, including the followings are strongly recommended.

Dissipating the charge with conductive materials

Preventing the charge generation with moisture

Neutralizing the charge with ionizer

(7) Others

When using the LEDs, it must care that the reverse voltage will not exceed the absolute maximum rating. The LED light is enough to injure human eyes, so it should avoid looking at LED light directly.

---

## **NOTE.**

---

All the information published is considered to be reliable. However, AOT does not assume any liability arising out of the application or use of any product described herein.

AOT reserves the right to make changes at any time without notice to any products in order to improve reliability, function or design.

AOT products are not authorized for use as critical components in life support devices or systems without the express written approval from the managing director of AOT.